

***Make Your
House a Home***



simfer

www.tafani.ae



We care about the future and respect the nature.

Energy Efficiency: Save energy and money by choosing an energy-efficient cooker.



Family is our top priority, and everyone in the family is safe.

Oven Safety Lock: It locks display functions, preventing accidental activation or modification of the settings.



Easy to Clean: The inner walls of the oven feature special enamel plates. The enameling is interspersed with so-called catalytic particles which cause predominantly fat deposits to be distributed over the enamel at temperatures starting from 180°C.

Low-E Glass: Low-Emissivity glass (Or Low-E glass as it is commonly referred to) is a type of energy-efficient glass designed to prevent heat escaping to the cold outdoors.



Flame Failure Safety Device: For added peace of mind, the flame failure safety device shuts off the gas if the flame becomes accidentally extinguished while cooking.

Induction Child Lock: The child safety lock safely prevents unintentional switch-on.

Steam Cleaning: Using this technology, you can easily clean your oven cavity. Put water into the tray and place your tray at the bottom level of your oven and set the operation knob. After the process, simply wipe away the residues using a soft cloth.

Easy to Remove Full Glass Oven Door: Full glass inner door making your cooker easy to clean with a single wipe.

90 cm Built-In Ovens



SMF908BOE-DT - ELECTRIC

Functions



Features

- Control Panel: Stainless Steel
- Front Door: Tempered Black Glass
- Oven: Electric (2000W)
- Grill: Electric (1500W)
- Extra Grill Function: Electric (2500W)
- Functions (Oven Control): 0+7
- Auto Cooling Fan: Yes (24W)
- Oven Door: Double Glazed, Full inner Glass without frame, Easy Remove
- Timer: 6 Touch Digital (Amber)
- Auto Cut-off: Yes
- Cavity: Flat, Enamelled Easy Clean Cavity
- Side Racks: Yes (Easy remove)
- Extra Accs.: 1x Trivet Grid + 1x Enamelled Round Tray
- Volume: 105 Liters
- (WxDxH) : 89.6 x 56.5 x 59.5 cm
- TL2023-2999



SMF908BOE-T - ELECTRIC

Functions



Features

- Control Panel: Stainless Steel
- Front Door: Tempered Black Glass
- Oven: Electric (2000W)
- Grill: Electric (1500W)
- Functions (Oven Control): 0+7
- Auto Cooling Fan: Yes (24W)
- Turbo Fan: Yes (1x 24W)
- Oven Door: Double Glazed, Full inner Glass without frame, Easy Remove
- Timer: Mechanic
- Cavity: Flat, Enamelled Easy Clean Cavity
- Side Racks: Yes (Easy remove)
- Extra Accs.: 1x Trivet Grid + 1x Enameled Round Tray
- Volume: 105 Liters
- (WxDxH) : 89.6 x 56.5 x 59.5 cm
- TL2023-2799



SMF903BOG-DT - GAS

Functions



Features

- Control Panel: Stainless Steel
- Front Door: Black Glass
- Oven: Gas (4000W)
- Turbo Heating Element: Electric (2x 1500W)
- Ignition: Auto Ignition
- Thermostatic Control: Yes
- Auto Cooling Fan: Yes (24W)
- Turbo Fan: Yes (1x 24W)
- Closed Door Grilling: Yes
- Timer: 3 Touch Digital
- Cavity: Flat, Enamelled Easy Clean Cavity
- Side Racks: Yes (Easy remove)
- Extra Accs.: 1x Trivet Grid
- Volume: 105 Liters
- (WxDxH) : 89.6 x 56.5 x 59.5 cm
- TCL2023-2899

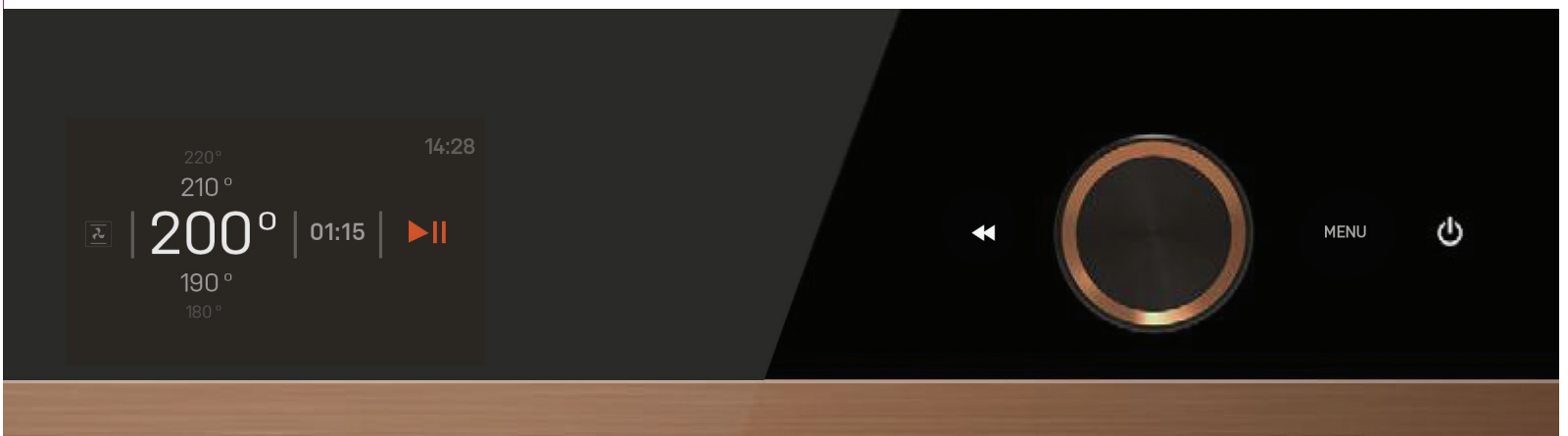

60 cm Built-in ovens



SMF609BOE-IQ - ELECTRIC

Functions



Features

- Control Panel: Stainless Steel
- Oven: Electric (1200W)
- Grill: Electric (1000W)
- Extra Grill Function: Electric (2000W) + Turbo ring element
- Functions (Oven Control): 0+8
- Auto Cooling Fan: Yes (24W)
- Turbo Fan: Yes (24W)
- Oven Door: Double Glazed, Full inner Glass without frame, Easy Remove
- Timer: 3 Touch Digital
- Cavity: Flat, GREY Enamelled Easy Clean Cavity
- Side Racks: Yes (Easy remove - 6 levels)
- Extra Accs.: 1x Enamelled Round Tray
- Volume: 82 Liters
- (WxDxH) : 59.5 x 56.5 x 59.5 cm
- TL2023-1699



SMF608BOE-DT XS - ELECTRIC

Functions



Features

- Control Panel: Stainless Steel
- Oven: Electric (1200W)
- Grill: Electric (1000W)
- Functions (Oven Control): 0+7
- Auto Cooling Fan: Yes (24W)
- Turbo Fan: Yes (24W)
- Timer: 6 Touch Digital
- Auto Cut-off: Yes
- Cavity: Flat, Enamelled Easy Clean Cavity
- Side Racks: Yes (Easy remove)
- Accessories: 1x Enamelled Tray + 1x Chrome Wire Grid
- Volume: 66 Liters
- (WxDxH) : 59.5 x 56.5 x 59.5 cm
- TL2023-1299



SMF603BOG-DT - GAS

Functions



Features

- Control Panel: Stainless Steel
- Front Door Decor: Bottom Inox Stripe
- Oven: Gas (1800W)
- Extra Grill Function: Gas (1500W)
- Functions (Oven Control): 1 Knob
- Ignition: Auto Ignition
- Auto Cooling Fan: Yes (24W)
- Turbo Fan: Yes (24W)
- Closed Door Grilling: Yes
- Timer: 3 Touch Digital (Amber)
- Cavity: Flat, Enamelled Easy Clean Cavity
- Extra Accs.: 1x Enamelled Round Tray
- Volume: 60 Liters
- (WxDxH) : 59.5 x 56.5 x 59.5 cm
- TL2023-1699

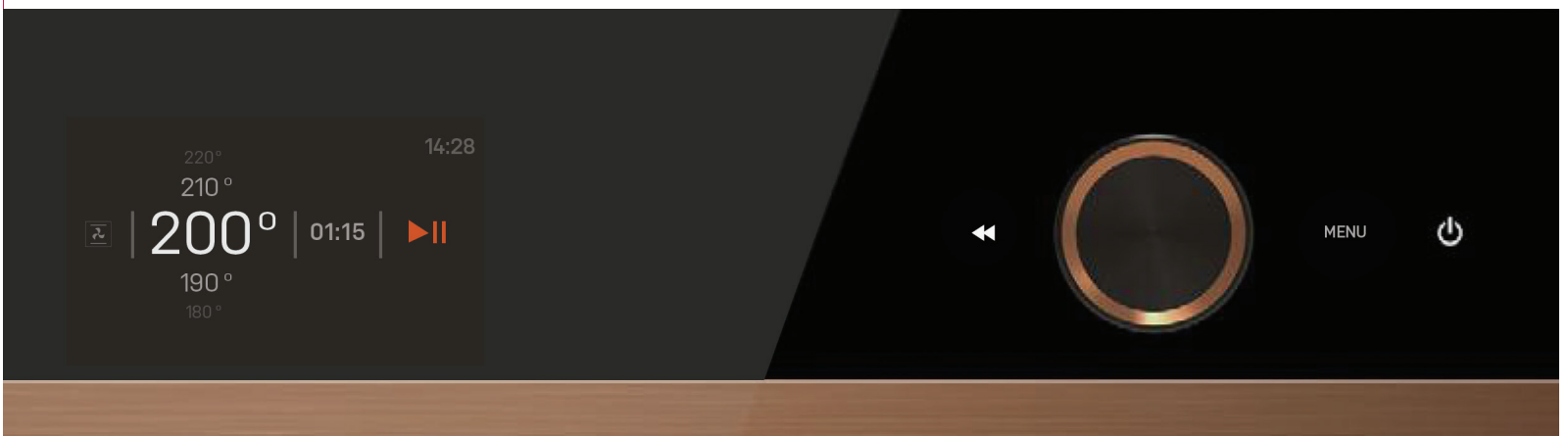

Ceramic Built-In Hobs

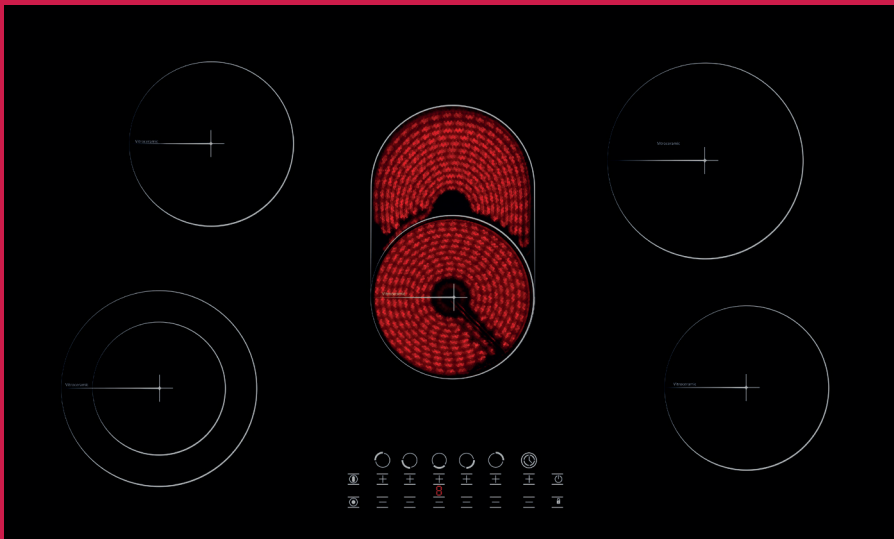

SMF9065BHVC

Features

- Top Plate: Black Ceran Glass
- Control Panel: Front, Touch
- Pan Supports: Cast-iron, Monoblock (P05)
- Led Illuminated Touch Panel
- Child Safety Lock
- Automatic Safety cut-out
- On Off Button with Hot Surface Alert Feature
- Easy Cleanable High-Resistance Glass Surface
- 9-Power Stages on each Cook Zone
- Hob Max. Power: 7700W
- Voltage: 380V
- TL2023-1799

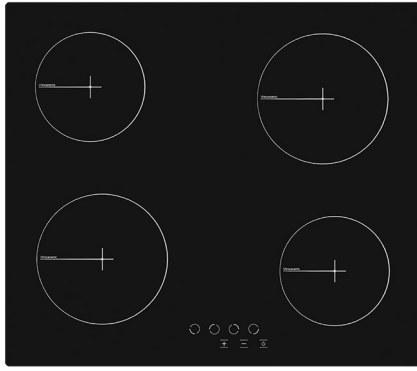

SMF6044BHVC

Features

- Hob Series: Flat
- Top Plate: Black Ceran Glass
- Control Panel: Front, Touch
- Led Illuminated Touch Panel
- Child Safety Lock
- Automatic Safety cut-out
- On Off Button with Hot Surface Alert Feature
- Easy Cleanable High-Resistance Glass Surface
- 9-Power Stages on each Cook Zone
- Hob Max. Power: 6000W
- Voltage: 380V
- Cable: Clemens Box
- TL2023-999

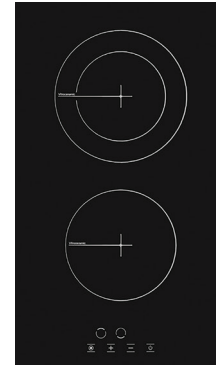

SMF3020BHVC

Features

- Hob Series: Flat
- Top Plate: Black Ceran Glass
- Control Panel: Front, Touch
- Led Illuminated Touch Panel
- Child Safety Lock
- Automatic Safety cut-out
- On Off Button with Hot Surface Alert Feature
- Easy Cleanable High-Resistance Glass Surface
- 9-Power Stages on each Cook Zone
- Hob Max. Power: 2900W
- Voltage: 380V
- Cable: UK Plug with Cable
- TL2023-599

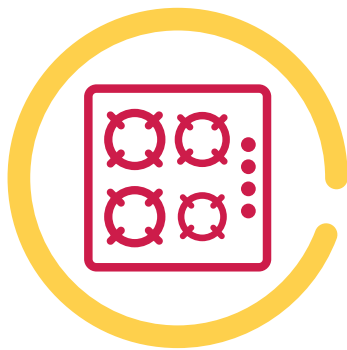

*Supported by
the quality,
design and
brand range
that others
can't deliver.*

Gas Built-In Hobs

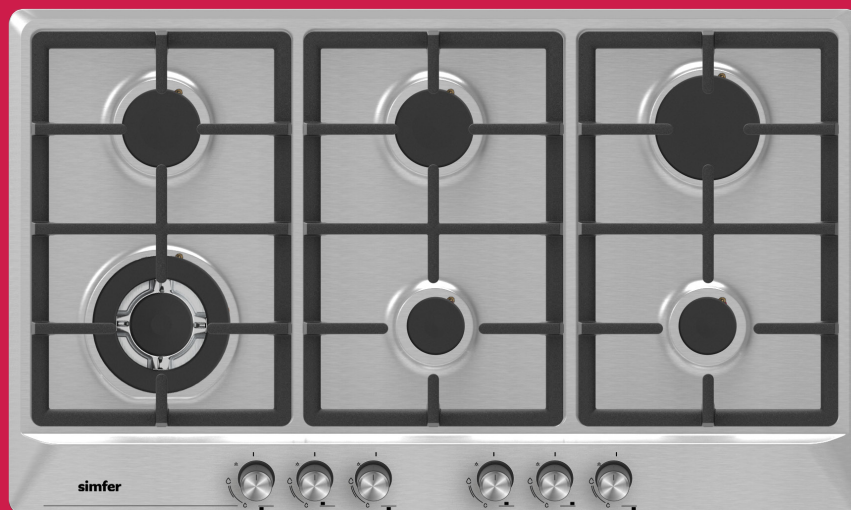

SMF909BH-SC

Features

- Hob Series: Wito
- Top Plate: Stainless Steel
- Control Panel: Front
- Pan Supports: Cast-iron, Monoblock (P05)
- Burner Caps: Flat, Enamelled, Matt
- Flame Failure Device (FFD): Yes
- Ignition: Automatic from Knobs
- Hob Max. Power: 14450W
- Voltage: 230V
- Cable: UK Plug with cable
- TL2023-1699



SMF907BH-SC

Features

- Top Plate: Stainless Steel
- Control Panel: Front
- Pan Supports: Cast-iron, Monoblock (P05)
- Burner Caps: Flat, Enamelled, Matt
- Flame Failure Device (FFD): Yes
- Ignition: Automatic from Knobs
- Hob Max. Power: 10850W
- Voltage: 230V
- TL2023-1199



SMF6406BHG-SC

Features

- Top Plate: Stainless Steel
- Control Panel: Front
- Pan Supports: Cast-iron, Monoblock L Type (P05)
- Burner Caps: Flat, Enamelled, Matt
- Flame Failure Device (FFD): Yes
- Ignition: Automatic from Knobs
- Hob Max. Power: 7250W
- Voltage: 230V
- TL2023-799



SMF6404BHG-SC

Features

- Top Plate: Stainless Steel
- Control Panel: Front
- Pan Supports: Enamelled, Monoblock (P05)
- Burner Caps: Flat, Enamelled, Shiny
- Flame Failure Device (FFD): Yes
- Ignition: Automatic from Knobs
- Hob Max. Power: 7250W
- Voltage: 230V
- TL2023-649



SMF303BHG-SC

Features

- Top Plate: Stainless Steel
- Control Panel: Front
- Pan Supports: Enamelled, Monoblock (P01)
- Burner Caps: Flat, Enamelled, Shiny
- Flame Failure Device (FFD): Yes
- Ignition: Automatic from Knobs
- Hob Max. Power: 3850W
- Voltage: 230V
- Cable: UK Plug with cable
- TL2023-549

Installation Diagram

90 CM BUILT-IN OVEN DIMENSION

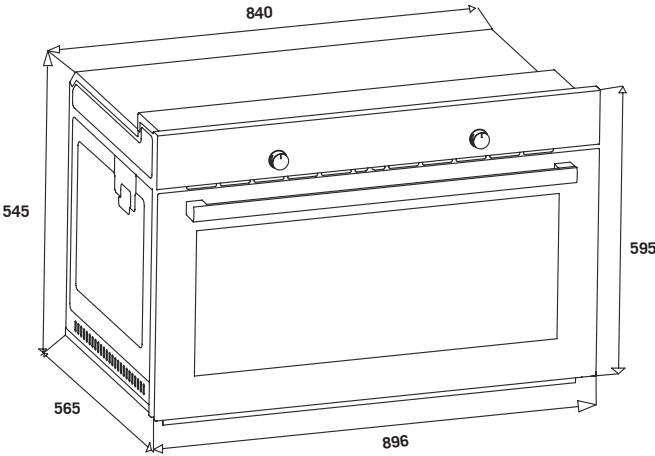

60 CM BUILT-IN OVEN DIMENSION

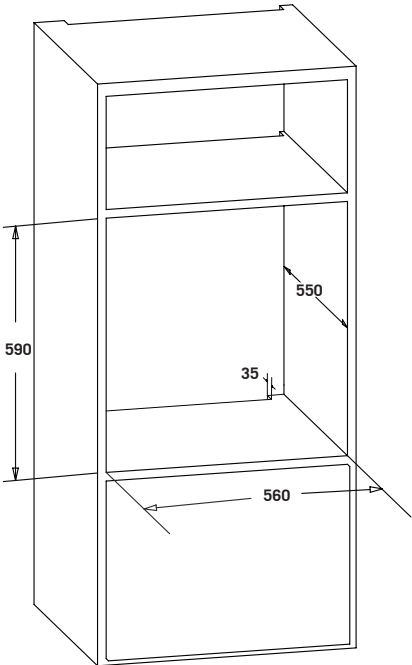
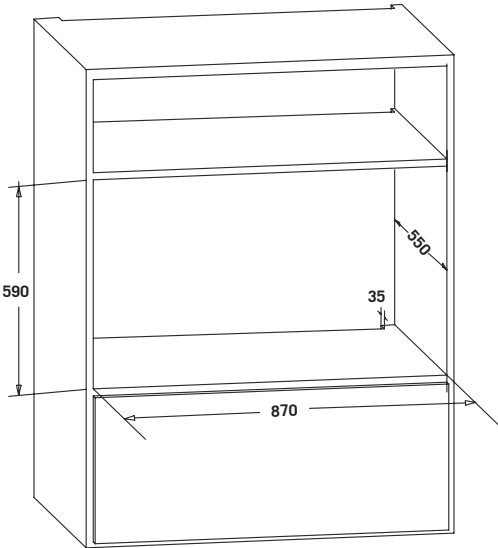
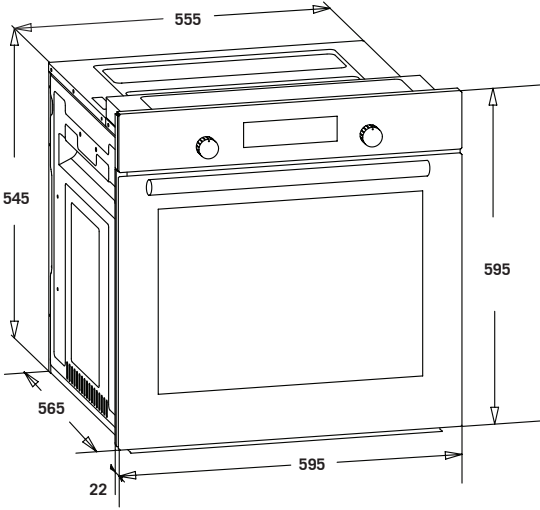

90 CM BUILT-IN HOB DIMENSION

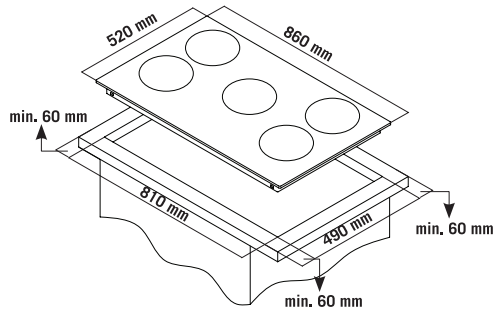

60 CM BUILT-IN HOB DIMENSION

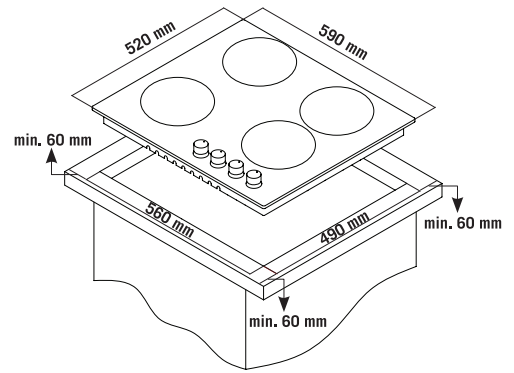

70 CM BUILT-IN HOB DIMENSION

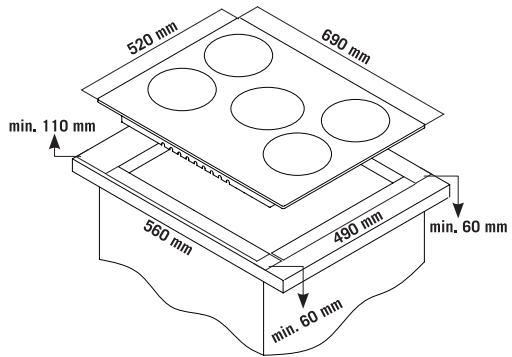

30 CM BUILT-IN HOB DIMENSION

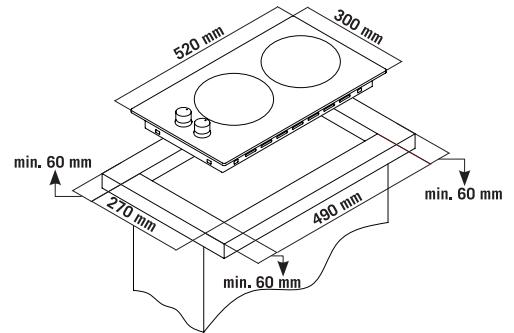

Welcome to **simfer** world with more than
1800 sales-points in **150** countries



With our **215,000** sqm production
site and **2000** employees

More than **2000** product range and
more than **280** service network



Advanced production

technology and
special designs
for our customers

Suitable for different cultures and
world class products..

We are Always with you..

Premium Cookers



SMF10067RG

Features

- 4 Gas Burners + 1 Triple Wok Burner (3,5 kW) + FFD + Automatic Ignition + Cast Iron Pan Support + 1 Vitroceramik Top Plate: 1 x Ø250 mm Oval - 1800 W Hi-Light Heaters
- Splashback
- Easy to Remove Side Wire Racks
- Removable Glass Door
- Bottom Left: 66 L.
- Top Left: 30 L.
- Top Right: 52 L.
- Bottom Right: 23 L.
- (WxDxH) : 100 x 60 x 90 cm
- TL2023-4999



SMF6264SS DC

Features

- 60*60 / 4 Gas / Gas 2 OVENS
- Ignition: Button Ignition
- Pan Supports: Heavy Cast-iron
- Grill Function: Gas (1500W)
- Cavity: Flat, Enamled Oven Cavity
- Side Racks: Yes
- Closed Door Grilling: Yes
- Timer: Mechanic Minder
- Inner Door Type: Tempered Glass
- Side Racks: Yes (Easy remove)
- Catalytic (Self Cleaning): Yes (Easy remove)
- (WxDxH) : 60x 60 x 85 cm
- TL2023-2499



SMF704WS2

Features

- 6 Gas Burners + 1 Triple Wok Burner (3,5 kW) + FFD + Automatic Ignition + Cast Iron Pan Support
- Digital Timer
- Fan Oven Function
- Top Left Oven Grill Resistance - 60 cm
- Top Right Oven Conventional Cooking - 50 cm
- Bottom Right Storage - 50 cm
- Bottom Left: 66 L.
- Top Left: 30 L.
- Top Right: 52 L.
- Bottom Right: 23 L.
- (WxDxH) : 100 x 60 x 90 cm
- TL2023-4999

Simfer creates products that can inspire you to make home cooking and living a richer, warmer experience.



Professional Cookers



SMF9066GR-BJ SP

Features

- 90x60 / 5 Gas / Gas Oven
- Product Type: Semi Professional
- Control Panel: Anthracite Black + Black Glass
- Oven Door Decor: "U" Type Anthracite Black Stripe
- Ignition: Auto Ignition
- Pan Supports: Heavy Cast-iron
- Functions (Oven Control): 2 Knobs
- Ignition: Auto Ignition
- Thermostatic Control: Yes
- Turbo Fan (2x): Yes (2x 24W)
- Oven Door: Double Glass Door, Full inner glass without frame and easy remove
- Timer: Analog Minder
- Cavity: Flat, Enamllled Oven Cavity (Roll Bond)
- Side Racks: Yes (Easy remove)
- Catalytic (Self Cleaning): Yes (Easy remove)
- Volume (Effective): 96 Liters
- (WxDxH) : 90 x 60 x 85 cm
- TL2023-3999



SMF9066SS SP

Features

- 90x60 / 5 Gas / Gas Oven
- Product Type: Semi Professional
- Ignition: Auto Ignition
- Pan Supports: Heavy Cast-iron
- Functions (Oven Control): 2 Knobs
- Ignition: Auto Ignition
- Thermostatic Control: Yes
- Flame Failure Device (FFD): Yes
- Turbo Fan (2x): Yes (2x 24W)
- Oven Door: Double Glass Door, Full inner glass without frame and easy remove
- Timer: 3 Button Digital Minder
- Cavity: Flat, Enamllled Oven Cavity (Roll Bond)
- Side Racks: Yes (Easy remove)
- Catalytic (Self Cleaning): Yes (Easy remove)
- (WxDxH) : 90 x 60 x 85 cm
- TL2023-3299



SMF9068CR SP

Features

- 90x60 / 5 Gas / Gas Oven
- Product Type: Semi Professional
- Ignition: Auto Ignition
- Pan Supports: Heavy Cast-iron
- Functions (Oven Control): 2 Knobs
- Ignition: Auto Ignition
- Thermostatic Control: Yes
- Flame Failure Device (FFD): Yes
- Turbo Fan (2x): Yes (2x 24W)
- Oven Door: Double Glass Door, Full inner glass without frame and easy remove
- Inner Door Type: Tempered Glass
- Timer: 3 Button Digital Minder
- Side Racks: Yes (Easy remove)
- Catalytic (Self Cleaning): Yes (Easy remove)
- (WxDxH) : 90 x 60 x 85 cm
- TL2023-3299

Aesthetic and durable cast iron pan support

Functional and durable cast iron pan supports could be cleaned easily.



Cooker Hoods



SMF8938

Features

- Model Type: 90cm Wall
- Material: Inox Body
- Type 1 - Push Buton (3spd): Push Button - Silver (3 Spd)
- Filter Saturation Warning: Yes
- Motor and Speed: 500m³/h (3SPD)
- Lamp: Led Light 1,5W x2 (122x33mm)
- Telescopic Chimney: 1X50Cm ,1x35 Cm (Min 50 Cm-Max 83 Cm)
- Remote Control: Yes
- Alm. Filter: Alm. Extrusion √x3
- Carbon Filter: Yes
- TL2023-1299



SMF 8933

Features

- Model Type: 90cm Wall
- Material: Inox Body
- Type 1 - Push Buton (3spd): Push Button - Silver (3 Spd)
- Motor and Speed: 500m³/h (3SPD)
- Lamp: Led Light 1,5W x2 (122x33mm)
- Telescopic Chimney: 1X50Cm ,1x35 Cm (Min 50 Cm-Max 83 Cm)
- Alm. Filter: Alm. Extrusion √x3
- Carbon Filter: Yes
- TL2023-849

Also available in 60cm



SMF 8689

Features

- Model Type: 60cm Wall
- Double Chimney: Yes
- Motor Spin: 3 Spin motor
- Control Type: Touch Control
- Display: Digital Led
- Filter cleaning warning: Yes
- Carbon Filter Change Warning: Yes
- Filter: Alm. Filter x1
- Lighting: 3x Led (3x 1W)
- Vacuum Power: 650 m3/H
- Control Panel: Black Glass with Inox Decor
- Remote Control: Yes
- TL2023-1399



SMF 8503

Features

- Model Type: 60cm Built-In
- Material: Silver Body
- Control Type: Rocker Switch - Silver (3 Spd)
- Motor and Speed: 280m³/h (3SPD)
- Lamp: Spot Led Light 5W x1
- Telescopic Chimney: 2x30 Cm (Min 30 Cm Max 58 Cm)
- ALM Fliter: Roll Forming Alm. √x1
- TL2023-299



SMF 7501

Features

- Model Type: 60cm Built-In
- Material: Silver Body
- Control Type: Push Button - Silver (3 Spd)
- Motor and Speed: 280m³/h (3SPD)
- Lamp: Spot Led Light 5W x1
- ALM Fliter: Roll Forming Alm. √x1
- TL2023-299

Microwave Ovens



MD 2880

Features

- 28 L.
- 8 Auto Cooking Program
- Grill Function
- Defrosting Function
- Programmable Digital Display
- Child Lock
- Microwave Power: 900 W
- TL2023-1099



MD 2890

Features

- 28 L.
- 8 Auto Cooking Program
- Grill Function
- Defrosting Function
- Programmable Digital Display
- Child Lock
- Microwave Power: 900 W
- TL2023-1299

Microwave Installation Diagram

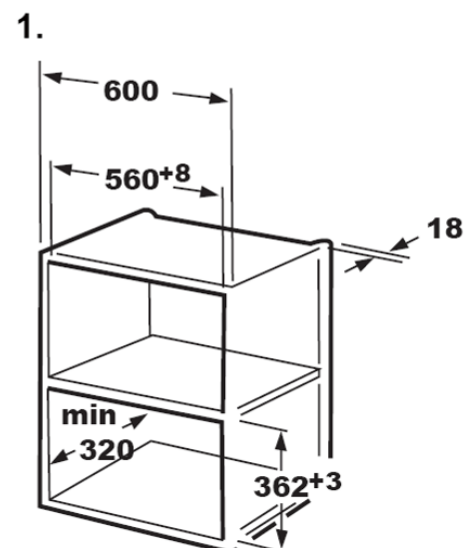
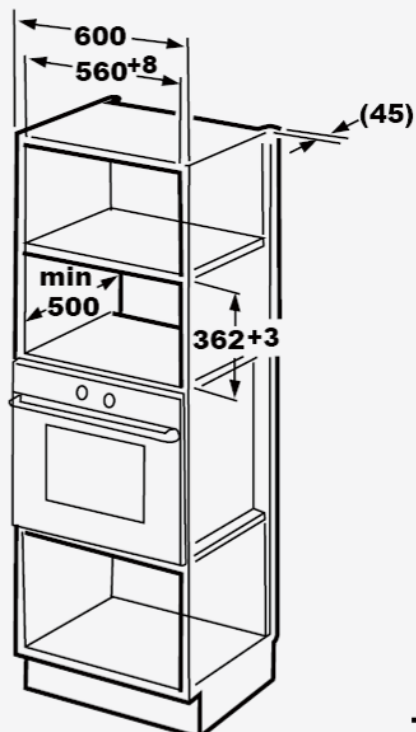

Washing



BM 1208

Features

- Digital Full Built-In
- 7 Program
- 14 Place Settings
- A++ Energy Level
- Noise Level: 47 dB
- Inox Display
- 10 L. Water Consumption
- Stainless Steel Finish Indoor Surface
- Rinse Aid and Salt Indicator
- Memory Function
- TL2023-2499



BM 1206

Features

- Digital Semi Built-In
- 7 Program
- 12 place settings
- A++ Energy Level
- Noise Level: 47 dB
- 11 L. Water Consumption
- Half Load (lower and Upper Basket)
- TL2023-2499



WM 13007

Features

- Capacity(kg): 7kg
- Color: White / Silver
- Motor: Universal Motor
- Drum Volume(L): 41
- Foam sensing & removal: Yes
- Number of program: 12
- TL2023-999

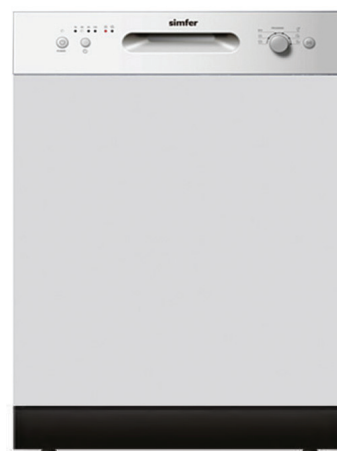

BM 1207

Features

- Digital Semi Built-In
- 6 Program
- 12 place settings
- A+ Energy Level
- Noise Level: 49 dB
- 12 L. Water Consumption
- TL2023-1999

Freezer



FS 7313 ENFK A+ D INX

Features

- . 7 Drawers No-frost Freezer
- . A+ Energy Class
- . Anti-finger print Stainless steel door and Silver body
- . Touch control digital display on door
- . Dual Mode
- . Electronic thermostat
- . Over Temperature Warning Function
- . Fast Freezing
- . 5 drawers and 2 flaps
- . Hot stamp drawer cover
- . Ice Tray and Ice bank
- . Gross / Net Volume: 300 / 290 L.
- . (WxDxH) : 59.5 x 71 x 176 cm
- . TL2023-2299



FS7305 NF A+S

Features

- . No Frost Cooling Technology
- . Electronic Cooling Control
- . Button Control Panel
- . 1x XXL Drawer With Transparent Cover
- . 4x Drawer With Transparent Cover
- . 2x Transparent Flap
- . Reversible Door
- . Fast Freezer Function
- . Adjustable Front Feet
- . Aluminium Handle
- . Ice Tray
- . 2x Wheel
- . Gross / Net Volume: 300 / 290 L.
- . (WxDxH) : 59.5 x 71 x 176 cm
- . TL2023-1999



User friendly electronic control panel

In addition to its ease of use, it also provides a stylish look to your freezer.



SMFBZ2513

Features

- Type: Refrigerator
- Color: White
- Freezer compartment star rating: 4 STARS
- Adjustable thermostat: Yes
- Voltage / frequency: 220-240V/50Hz
- Ice cube tray(s): yes
- Egg Trays: Yes
- (WxDxH) : 177 x 44 x 44 cm
- TL2023-2099



SMFBZ2516

Features

- Mini Built-in Refrigerator
- 111 Lt Total Net Volume
- 95 Lt Refrigerator Net Volume
- 16 Lt Freezer Net Volume
- Static Cooling System
- Electronic Control System
- F Energy Class
- (WxDxH) : 59.6 x 55 x 82cm
- TL2023-1599



Chest Freezers



CS6600 A+

Features

- Triple Mode (Fridge, Freezer & Chiller)
- Gross Capacity: 600 Litres
- Net Capacity: 561 Litres
- R600a Refrigerant
- Led Ampule Light
- Lock
- Mechanical Thermostat
- (WxDxH) : 177.5 x 74.3 x 84 cm
- Power Supply: 220 - 240 Volts
- TL2023-2299



CS4420 A+

Features

- Triple Mode (Fridge, Freezer & Chiller)
- Gross Capacity: 600 Litres
- Net Capacity: 561 Litres
- R600a Refrigerant
- Led Ampule Light
- Lock
- Mechanical Thermostat
- (WxDxH) : 131.6 x 74.3 x 84 cm
- Power Supply: 220 - 240 Volts
- TL2023-1799

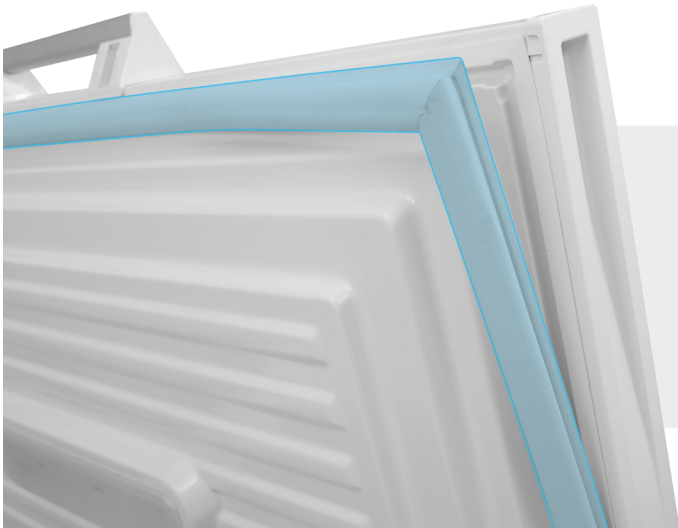

Easy to remove
door gasket

Door Gasket system designed for
easy remove and replacement.

A+ Chest Freezers



CS 3320 A+

Features

- Triple Mode (Fridge, Freezer & Chiller)
- Gross Capacity: 305 Litres
- Net Capacity: 295 Litres
- R600a Refrigerant
- Led Ampule Light
- Lock
- Mechanical Thermostat
- (WxDxH) : 104.1 x 74.25 x 84 cm
- TL2023-1699

Best performance at all conditions!

Simfer chest freezers produced with SN-T Climate Class. This technology enables freezer to operate under Tropical, Sub-Tropical, Normal and Sub-Normal climate conditions.

Maximum performance in all external temperatures.



تفاني
Tafani
a member of Tanseeq Group

T: +971 4 243 4010

F: +971 4 243 3969

E: info@tafani.ae

Suite 601 | Building 11
Bay Square | Business Bay
PO Box 3151 | Dubai | UAE

www.tafani.ae

simfer